



**MTG**

No limits innovation



**INS.1.1.2**  
**TWINMET**  
**3-Part Tooth System**  
Installation procedure

## DISCLAIMER

### © MTG, all rights reserved

The brands identified with an asterisk do not belong to METALOGENIA S.A. and this organization refers to them only to identify the destination of its products, without there being any relationship between METALOGENIA S.A. and the legitimate owners of any such brands.

**Copy right:** It is strictly forbidden for any person not belonging to MTG to distribute all or any part of the material set out in this document unless they are authorized to do so.

**Liability:** To ensure the correct use and handling of the MTG products without risk, please carefully read the corresponding service instructions set out on the MTG website. MTG will not be held liable for damages, loss, injury, or death arising from incorrect use or failure to heed the provisions of this guide. Similarly, MTG will not be held liable for damages caused due to the faulty installation or handling of its products. MTG likewise declines all liability for recommendations related to the use or handling of MTG products set out in documents not expressly authorized by MTG.

## 1. SAFETY

The practices described in this manual can be taken as guidelines for operating safely in many conditions and in addition to the safety standards that are current and enforceable in your area or region.

Your safety and the safety of third parties is the result of putting into practice your knowledge of the correct operational procedures.

Attention, when performing the work described in these instructions, always work safely and use the personal protection elements required to minimize or avoid injury. Always wear:



To avoid eye injury, always wear safety goggles or a protective mask when using any equipment, hammer or similar tool. When equipment is under pressure or when objects are struck, chips or other debris can be thrown out. Make sure no one gets hurt by the debris that is fired before applying pressure or hitting an object. Wear eye protection that complies with ANSI Z87.1 and OSHA standards. Also wear hearing protection and gloves.

Lifting a heavy object can cause serious or fatal injury. DO NOT exceed the maximum rated capacity of lifting and positioning devices: Stay away from the area under a suspended load.



**LIFTING LUG**

Make sure that the chain is not damaged and that the load is always balanced.

## 2. LOCKING PINS

This system allows the installation of 2 different types of pins, regular and self-extracting (see images). This procedure includes the assembly and disassembly of both.

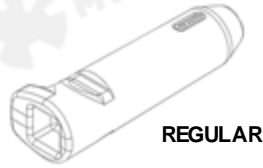

## 3. INSTALATION PROCEDURE

### NOTES:

- Neither the steel retainer nor the pin are reusable, especially for safety reasons.
- When interchanging or rotating positions for any reason, involving the process of disassembly, a new pin and retainer **MUST** be installed.
- The installation procedure is the same regardless of the type of pin used, regular or self-extracting.



**3.1** Ensure that the spring retainer is duly placed on its assembling position. If so, advance to step 3.5, otherwise follow to the next step.

**3.2** Place the spring retainer on the opened groove until it remains anchored/fixed.

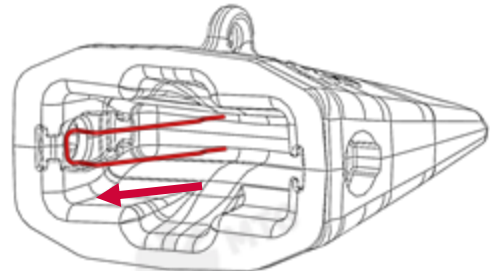
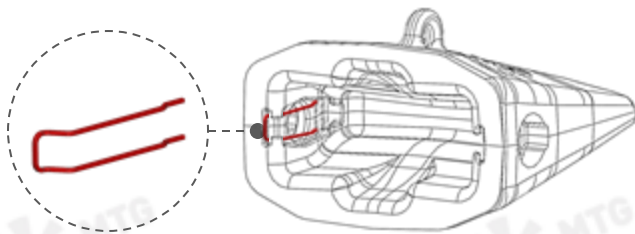

**3.3** Press slightly both ends of the spring retainer and turn them towards the 2nd groove (internal side) to let both extremes anchored inside the groove.

**3.4** Release the pressure on the retainer once placed inside the groove and check if it has opened and is on its final position.

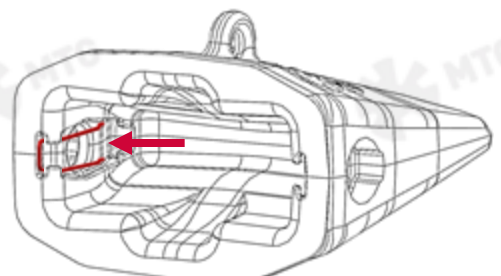
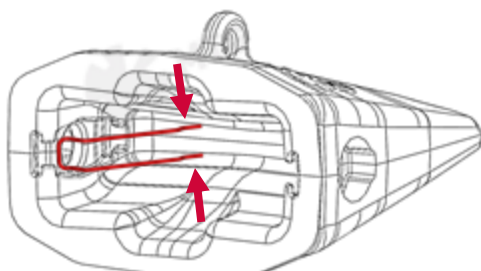

**3.5** Insert the tooth in the intermediate adapter.

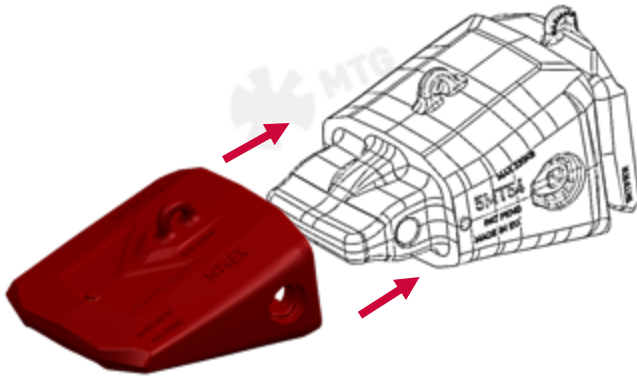

**3.6** Introduce the pin pushing and twisting it with the tool at the same time to ease its introduction.

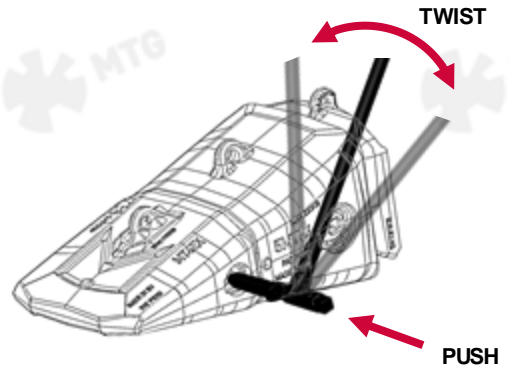

**3.7** When the pin reaches its final position, the pin flange must be aligned to its housing.

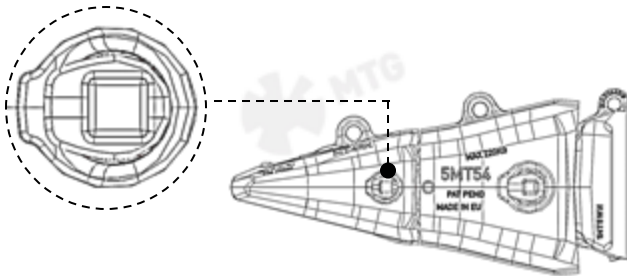

**3.8** Once the pin is blocked (working position) a "Click" sound must be heard.

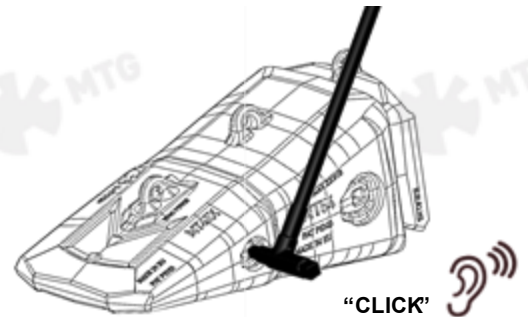

**3.9** Repeat the previous steps (3.1 - 3.8) with the pin of the other side.

## 4. REMOVAL PROCEDURE

**NOTE:** Prior to start the removal procedure, check that the lifting lug is still suitable to be used. If the lifting lug is damaged, or with clear sings of wearing, proceed to weld a new lifting lug capable to withstand 100kg.



### 4.1 REMOVAL OF REGULAR PINS

**4.1.1** Clean the fines stuck inside the pin square hole drive. Then insert the removal tool and turn the pin 90° either way to unlock the pin from the retainer.

If the pin is hard to turn, do not force it and proceed with several sway movements to break the fines stuck inside the hole. A rattle gun can be used for this operation.

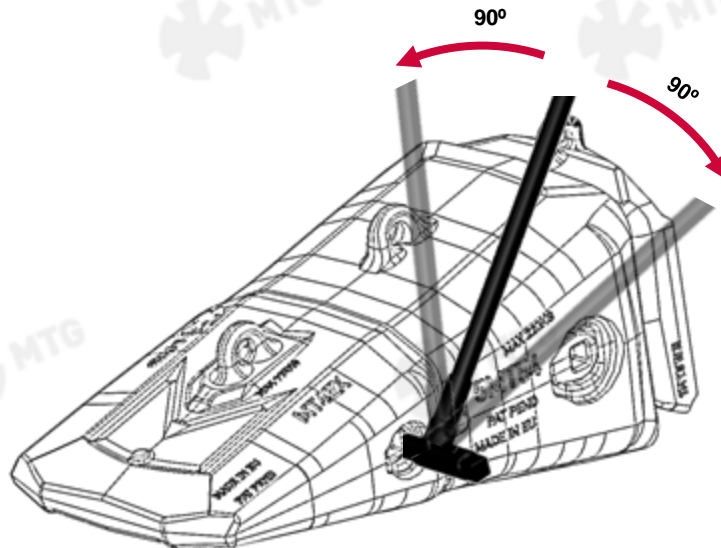

**4.1.2** Once the pin has rotated 90° extract it from its housing by pulling and twisting it using the removal tool.

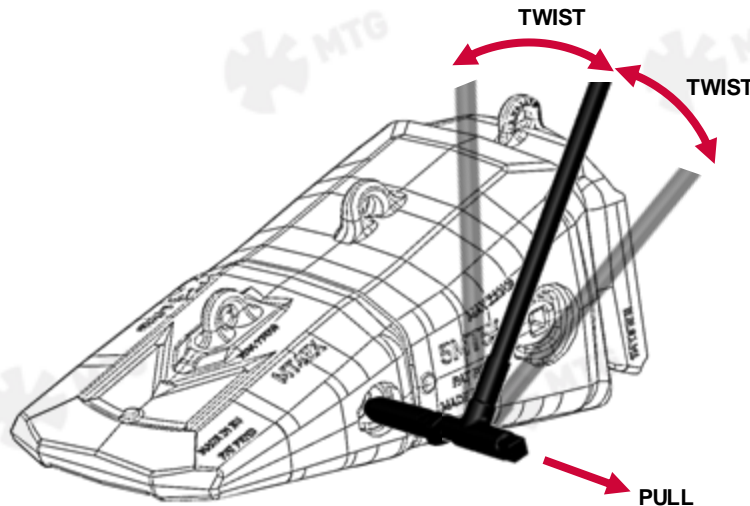

**4.1.3** Repeat the previous steps 4.1.1 & 4.1.2 with the pin of the other side.

## 4.2 REMOVAL OF SELF-EXTRACTING PINS

**4.2.1** For the removal of the self-extracting pin, the use of a pneumatic or electric rattle gun with a torque of at least 1000 Nm (738 lbft) is required. The torque indicated is in a counterclockwise or loosening direction.

The pin's square drive socket dimension is 1", so the rattle gun square drive must be of the same size, or an impact coupling must be available to convert to that size.

To proceed with the disassembly, clean out first the fines stuck inside the pin's square cavity. Then insert the rattle gun and turn the pin counterclockwise (or loosen).

The pin's grooves, together with the turning action, will pull the pin out of the pin cavity until it can be removed by hand.

If the pin is difficult to turn, the turning direction of the rattle gun may be alternated (clockwise and counterclockwise) in order to break the fines stuck inside the hole, provided that the direction of rotation of the pin for disassembly is counterclockwise.

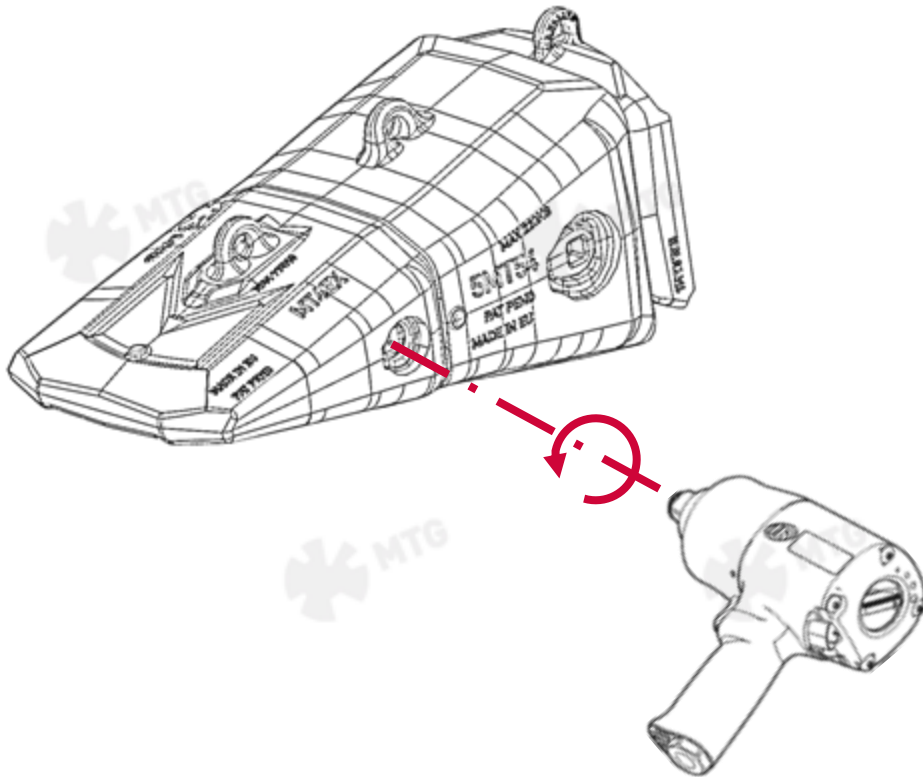

**4.2.2** Repeat the operation with the pin of the opposite side.



## Service Instructions

The latest welding recommendations and assembly / disassembly instructions can be found online:

[www.mtgcorp.com/manuals](http://www.mtgcorp.com/manuals)

Please contact Technical Services in case of questions:

[technical.services@mtg.es](mailto:technical.services@mtg.es)



---

### MTG HEADQUARTERS

Carrer d'Àvila, 45  
08005 Barcelona (Spain)  
(+34) 93 741 70 00  
info@mtg.es

### MTG NORTH AMERICA

4740 Consulate Plaza Drive  
Houston, TX 77032 (USA)  
+1 (281) 872 1500  
info@mtgcorp.us

### MTG AUSTRALIA

16 – 18 Thorpe Close  
Welshpool, WA, 6106 (AUS)  
+61 8 6248 6513  
Info.australia@mtg.es